

BLOCK WATCH

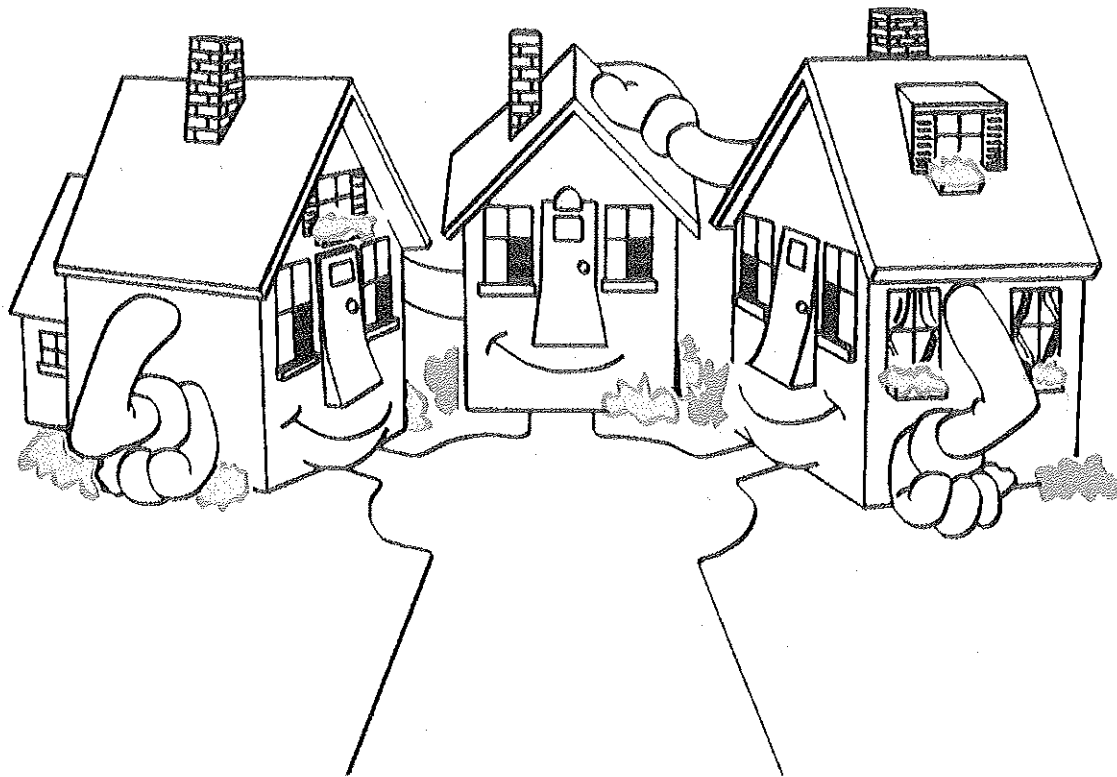

Captain and Co Captain Manual

**An operation manual for the
Block Watch Program**

For Safer Communities

Block Watch and the accompanying logo are the registered trade marks of the Block Watch Society of B.C.

WHY BLOCK WATCH?

CONTENTS:

PROGRAM OVERVIEW	3
RUNNING BLOCK WATCH - RESPONSIBILITIES	4, 5
THE BLOCK WATCH MAP	6
HOLDING A BLOCK WATCH MEETING	7, 8
MAINTAINING BLOCK WATCH	9
APARTMENTS, TOWNHOMES AND MOBILE HOMES	10
MASTER LIST	11

In recent decades, policing has changed dramatically. Historically, police have used a reactive style of law enforcement. In other words, they responded to your complaints. A growing population, budget cuts and other factors have forced them to rely on you, the public, more than ever. Consequently, community policing has arrived. The police are establishing a base within communities in an effort to fight crime on an altogether different level.

In 1986, this model of community policing led to the development of Block Watch. Block Watch works out of your local police department or community police office. Its personnel usually consists of one coordinator, which may be a police officer or a civilian, and in some offices, one or more assistant coordinators.

Your Block Watch office is not always able to have direct contact with the general duty or burglary section members of the police force. Therefore, the Block Watch office may be unaware if a break-in occurs on your block. So communication between you and the office is of utmost importance. *We need to hear from you!* Participation in the program is the key to its success.

The program has been influential in arresting criminals, and, in general, reducing crime. It also promotes increased feelings of neighbourhood security.

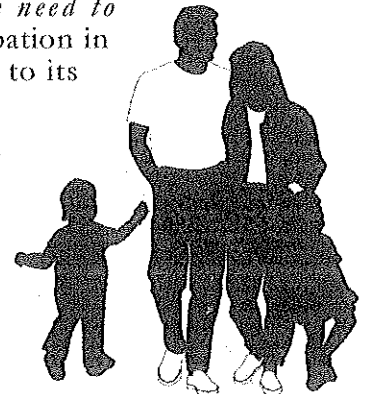

CONGRATULATIONS ON VOLUNTEERING ...

EVERY SUCCESSFUL PROGRAM NEEDS LEADERS LIKE YOU!

- Block Watch is a way to have neighbours watch, and communicate with each other and police.
- Block Watch involves being alert.
- Block Watch involves being aware of your neighbours property as you would your own, and a commitment to reporting suspicious activity to your police and neighbours.
- Your involvement and leadership is the key to success.

BLOCK WATCH OVERVIEW

WHAT BLOCK WATCH IS:

Block Watch is an extension of what you may already be doing on a daily basis. Many of us have watched our neighbour's home for them when they are away or at work, as a favor. Under Block Watch that watchfulness is broadened and becomes more systematic. All residents on a block get to know each other through participation and communication to keep an eye out for each other.

Block Watch involves being alert as part of your everyday life. For example, when you go to a window to close the drapes, take the time to look around the neighbourhood. Ensure everything is as it should be. Talk to your neighbours to keep them aware of current crime prevention techniques and news of local crime trends.

The program involves two commitments: The first is be concerned about your neighbour's property as you would your own. The second is to report suspicious or criminal activity to the police and to your neighbours.

WHAT BLOCK WATCH ISN'T:

Block Watch does not require you to perform special tasks or go to a lot of meetings.

You do not patrol the neighbourhood or chase burglars.

You aren't required to live in your neighbour's hip pocket. You can still conduct your life in privacy.

Block Watch doesn't require that you be any friendlier than you want to be.

Block Watch isn't just for homeowners. The tips and techniques are equally valuable to tenants.



Aims and Objectives of the Program ...

- Reduce residential crime
- Improve police/public relations by "working together"
- Establish a sense of community with neighbourhoods
- Make our communities a better place to live, work, and raise our children

Crime is a community problem that requires community response!

As a Captain or Co-captain:

- You are a neighbourhood communication consultant.
- You are **NOT** ...
 - the neighbourhood patrol
 - responsible for the security of your neighbours
 - expected to give up any privacy

Block Watch isn't just for homeowners – all tips and techniques apply equally for tenants.

RUNNING BLOCK WATCH...

The primary function of the Block Captain is to set up communication between neighbours and serve as the link between Block Watch participants and the Block Watch office. The Block Watch Captain or Co-Captain is not responsible to keep crime off the block, to patrol the area or be responsible for everyone's house keys when they are on vacation.

Being alert to crime and its prevention is the responsibility of everyone on the block.

CAPTAIN AND CO-CAPTAIN RESPONSIBILITIES

Serving as a Captain is not time consuming and you do not have to be home at all times to volunteer. Captain and Co-Captains don't have to perform all their duties alone.

ASK OTHERS ON THE BLOCK TO HELP OUT WHEN NECESSARY.

Before becoming a Captain or Co-Captain you must undergo a security clearance. You must also undergo training (where most Captains or Co-Captains receive this manual). If you haven't completed these steps, please contact your Block Watch office.

DRAW UP A MAP AND PARTICIPANT LIST

You are not officially on the Block Watch Program until the Block Watch office receives a copy of your map and participant list. See page 6 for instructions on this process.

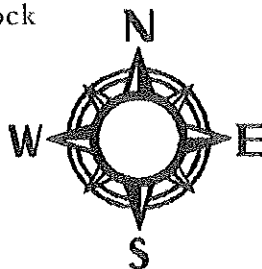

COMPLETE COMPUTER FANOUT FORMS

This will allow you to receive messages from the Block Watch office, generated by a computer system. (Please note: Not all programs have this system in place.)

ORGANIZE AT LEAST ONE MEETING PER YEAR

Neighbours meet to create a sense of 'community', and to also create a common bond with one another regarding crime prevention. *Every meeting should be considered as important as the first!*

Block Watch groups should meet formally at least once a year to renew acquaintances and meet new neighbours. It's also useful to review block problems and find solutions. Occasionally, new Captains and Co-Captains can be selected at these meetings.



These meetings can also be used to educate the block about the program and pass on security advice received from the Block Watch office.

CONDUCT MANUAL FANOUTS

Manual fanouts are a method of contacting neighbours to inform them of any incidents, crime trends, suspicious activity and updated Block Watch information.

It is the Captain's and Co-Captain's responsibility to keep everyone informed and aware of what is going on in your neighbourhood.

The Block Captain may wish to set up a telephone tree. It is a system where Block Watch members are assigned to call other members with information. This lessens the burden on the Captain or Co-Captain and helps speed up communication.

CAPTAIN AND CO-CAPTAIN RESPONSIBILITIES

DISTRIBUTION OF NEWSLETTERS

Newsletters are an important communication tool. Deliver them to participants personally. This gives you another opportunity to exchange information with them. It also helps you keep tabs on what's happening on your block.

DISTRIBUTE MANUALS AND EQUIPMENT

Engravers, decals, manuals and other handouts are available at no cost. Block homes can borrow an engraver from their Captain or Co-Captain to mark their valuables. After a participant has engraved their valuables, they can obtain Block Watch decals from their Captain or Co-Captain. The decals are displayed at entrance ways to show that valuables are marked for police identification.

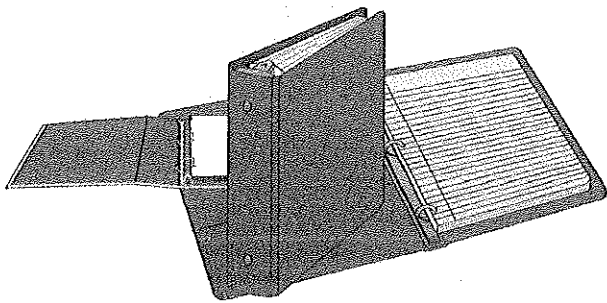

COMMUNICATION WITH THE BLOCK WATCH OFFICE

Stay in contact with your Block Watch office. Ensure that they have an updated Block Watch map, with current names and phone numbers. The office will also photocopy your maps and lists, so you can distribute them to your block. Report any crimes or suspicious activity that occurs on your block to the police first and then to the Block Watch office.

PROPER COMMUNICATION

Contact new neighbours who move onto the block, invite them to join the program and forward information to them. Encourage participants to inform you when they witness suspicious activities, crimes or any other block problems.

Remind them to call the police first, then the Captain or Co-Captain, who will in turn inform the Block Watch office.



PRACTISE CRIME PREVENTION STRATEGIES

PROVIDE A GOOD EXAMPLE TO YOUR BLOCK BY PRACTISING GOOD

CRIME PREVENTION STRATEGIES IN YOUR HOME:

- Engrave valuables and display decals.
- Leave front and rear outside door lights on all night.
- Secure doors and windows each time you go out.
- Examine and modify landscaping and shrubs to make your home more visible from the street. This includes eliminating potential hiding places for criminally-minded individuals.
- Lock your cars and bring valuables inside.
- Put away tools, ladders, etc.
- Tell the neighbors when you will be away.
- Watch for suspicious activity or strange vehicles.
- Call police when necessary.
- Call your Block Watch office to discuss crime prevention measures.

THE BLOCK WATCH MAP

YOU NEED TO CREATE A BLOCK WATCH MAP. HERE'S HOW:

Keep it simple and don't worry if you are not an artist. Make your map functional and clear and concise. Mark the street names and house numbers on it. Also, include the names and phone numbers of the block members or attach a list.

Make the map suitable for everyday communication among block members. Be sure it's easy to use in the event of an emergency. Also, put compass directions on the map.

Include important phone numbers, such as emergency and non-emergency numbers of police fire and ambulance (if applicable). Add the Block Watch office number and your block identification number for their reference.

Be sure to update the map regularly and send a copy to both the Block Watch office and block members. Date the map to indicate how current it is. Keep your map near the phone, but out of sight. If it got into the wrong hands, it could cause you and your block a lot of problems.



MAP OPTIONS

Some block members may not wish to disclose their phone number to other residents. In these cases simply write *UNLISTED*.

If they permit, list their business phone number instead. Check to see if these participants are willing to give their unlisted numbers to you and the Block Watch office for message fan-out and emergency purposes.

Remind them that Captains and Co-Captains are security-cleared and reassure them that the number will be kept confidential.

If your block is uncomfortable with a particular neighbour being part of your Block Watch (and subsequently having a map and list of participants), it is certainly permissible to exclude that

BLOCK WATCH MAP			
BLOCK NO: <u>1</u>			
Police Emergency Phone: _____			
Police Non-emergency phone: _____			
Block Captain: <u>S. Barry</u>			
Co-captain: <u>R. Inglis</u>			
Date: <u>Aug. 23, 1998</u>			
412	RED INGLIS 555-1111 CO-CAPTAIN	411	SAM & MARY SMITH 555-1132
410	CAL & DI YOUNG 555-1131	409	BILL JONES 555-1235
408	QUAN & HO LEE 555-1151	407	RON JENKIN 555-1158
406	BASHIR BARRY 555-1177 BLOCK CAPTAIN	405	SAM BOURN 555-9177
404	HELEN REEVE 555-1190	403	JOHN J. RANKIN 555-1234
402	GEORGE CHEEKS 555-1132	401	ROB CLOWDER 555-1875
400	JOE PITRE 555-1135	399	DON PLUM 555-9753
398	SAL ROSIE STONE 555-1177	397	JAKE JASPER 555-8743
Mountain Place		Ridge Road	

neighbour. For example, this neighbour might be someone who is creating the problems on your block that you are trying to eliminate.

You can include names and street addresses of the people in the homes that back onto your block. Record this information on member's personal maps. It need not be added to the block's master copy that's kept at the Block Watch office. This can be helpful if block members observe suspicious activity occurring on the next block over.

Consider including:

- Business or work numbers.
- Cellular phone or pager numbers.
- The names and ages of block children.
- Block members' vehicles, including make and model, as well as plate numbers and colour.
- Alarms that are installed on the block.

HOLDING A BLOCK WATCH MEETING



HERE ARE SOME THINGS TO REMEMBER WHEN PREPARING FOR YOUR BLOCK WATCH MEETINGS:

Determine where the meeting will be conducted. It can be held at the Captain's or Co-Captain's home or at another designated home. You can also look into holding it at a local community facility, such as a school or community centre.

Speak to everyone who you would like to attend. Explain that you are the block captain, who has been trained to organize Block Watch in the neighbourhood. Advise them on when and where the Block Watch meeting will be held. You can ask your police department to send an officer to attend your meeting. This service may not be available in all areas, so check with your Block Watch office. Officers are usually available Monday through Thursday, but be sure to give them 10 to 14 days notice.

In the event of emergency police business, a scheduled officer may have to cancel.

Block Watch videos can be borrowed free of charge for your meeting. They are approximately 10 minutes in length and cover a variety of subjects, including general information and crime prevention tips. Call your Block Watch office to reserve copies.

The block meeting is the best time to compile data for the block map and participant list. Distribute manuals, handouts, etc. Encourage everyone to write down any suspicious activity when they witness it. This information can be invaluable to a police investigation.

Remind people to use the Suspect Identification pull-out in their Participant's Handbook. Make arrangements to circulate the engraver and remind people that they will receive their decals, once their valuables have been engraved.

Implement a manual telephone fanout system. Have participants sign computer fanout forms (if applicable).

Don't be disappointed if some neighbours don't show up. This is quite common and doesn't mean that they are not interested. After the meeting, contact those that did not attend and encourage them to participate and collect the missing data for your map.

Distribute the map and participant list to everyone. After the meeting, please call the Block Watch office and let them know how the meeting went. If you need further assistance, this is a good time to ask.

INTRODUCTION

Provide everyone with name tags. Introduce yourself and ask everyone to introduce themselves and identify where they live.

Thank everyone for coming and then briefly explain why you have taken the steps to organize Bloc Watch. Ask the participants to share information with the group about any problems they have encountered on the street or in the complex.

THE BLOCK WATCH VIDEO AND HANDBOOK

Show a video that you feel is appropriate for the group. Obtain a list of titles from your Block Watch office. Give a copy of the Participants Handbook to everyone and point out that it provides general information about home security. Suggest that they call the Block Watch office if they need further help with home security.

THE ENGRAVER

Discuss the engraver and why it is useful in protecting valuable belongings. Tell them that they can borrow it for three days at a time. Set up a schedule to circulate it. Tell them that door decals are available to them once their contents have been engraved. Remind them to engrave their drivers license number. Social security numbers are no longer used due to the Privacy Act. If they don't have a driver's license suggest they use a friend's or relative's number.

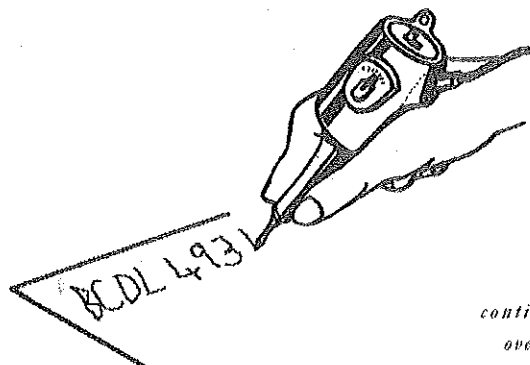

*continued
overleaf*

HOLDING A BLOCK WATCH MEETING

continued from previous page

HOME INSURANCE

Discuss home insurance issues. Tell them that some companies give discounts to members of Block Watch.

Suggest that they photograph or video-tape valuables and make an inventory of their household items. Keeping a file of sales receipts is also a good idea. All these precautions are useful during an insurance claim.

MANUAL FANOUT

Discuss the implementation of the Manual Fanout System on your block.

Communication is key to the success of the program and it is imperative they report any suspicious activity to the Captain or Co-Captain. Remember, when necessary: **Police should be called first.**

COMPUTER FANOUT

Discuss the computer fanout program if it is available in your area. Be sure everyone who is interested fills out and signs the permission form. See page 9 for description of this system

ADVICE TO THOSE WITH ANSWERING MACHINES

Be aware that when our computer encounters your machine it will "think" that an actual person has answered and will begin transmitting its message. If this happens and you miss information, or you need to receive more information, contact your Block Watch office for complete details.

It is important all household members are aware that these messages will be sent on occasion.

Messages of a sensitive nature (i.e. sexual assaults) may be sent on occasion, but will NOT contain explicit details.

THE BLOCK MAP

Explain why and how the Block Map is used.

Complete the map at the meeting. Remind everyone to keep it in a handy place that's out of sight. Tell participants to ensure that their house numbers are lit and are visible from the street. Tell them this also helps emergency vehicles find their home.

NEWSLETTERS

Tell block members that they will receive the quarterly newsletters from the Captain or Co-Captain. Explain its purpose. (This may not be available in all areas.)

CALLING THE POLICE

Tell participants to obtain a police file number if they have to call the police. This will help in the future if they want to follow up on the case.

WRAP UP

If you do not have a Co-Captain, ask for volunteers. Decide how often your block should meet. Answer questions and deal with any other business at hand.

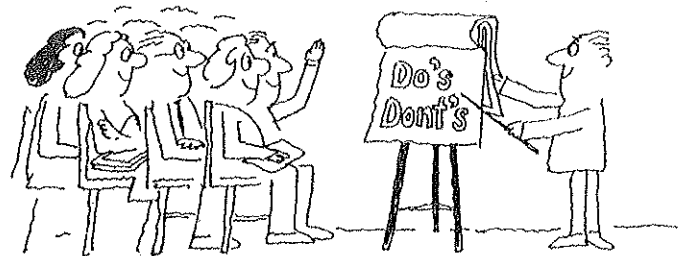

MAINTAINING BLOCK WATCH

COMMUNICATION IS THE KEY TO MAINTAINING THE BLOCK WATCH PROGRAM. HERE ARE SEVERAL WAYS YOU CAN COMMUNICATE EFFECTIVELY:

NEWSLETTERS



Where available, newsletters are produced quarterly and should be delivered to every participant via the Captain or Co-Captain. They may include crime tips, area pin maps and information relating to suspicious persons, vehicles, activities or seasonal newsworthy items.

PERSONAL CONTACT

Newsletters should be delivered in person so that Captains and Co-Captains can have added contact with participants and exchange additional information.

CONTACT WITH YOUR OFFICE

The Block Watch office tries to maintain ongoing contact with all Captains on a regular basis. In larger programs, Area Coordinators assist by acting as a liaison between a number of Captains and the Block Watch office.

MESSAGE FANOUT SYSTEM

The message fanout system is a method of communicating information to your block. It comes in two forms: the **Manual Fanout** and the **Computer Fanout**.

BENEFITS OF THE FANOUT SYSTEM INCLUDE:

- Information of interest to Block Watch participants can be quickly transmitted and communicated. Information regarding crime trends occurring in a specific area can be distributed to participants to raise awareness.
- Descriptions of suspects active in residential break and enters or in vehicle thefts can be communicated.

1. THE MANUAL FANOUT

If any message is relayed to the Captain or Co-Captain from participants or the Block Watch office regarding suspicious activities or occurrences, then the manual fanout system must be implemented as soon as possible. It's a system whereby the Captain or Co-Captain (or designated block members) call block participants to relay the information.

2. THE COMPUTER FANOUT

(Not in use in all areas)

The Block Watch office uses this system to transmit prerecorded messages to a specific group of participants via a computer hooked up to a phone.

This system includes all Captains and Co-Captains and is mandatory for them. It also includes those participants who have indicated (on a consent form) that they wish to receive computer fanout messages.

The computer is able to recognize busy signals and no-answer calls. It tries to call participants more than once if it detects a busy signal or if a call is unanswered. When placing these calls, the Block Watch office identifies itself immediately. The system calls at a reasonable hour.

Some people choose not to be part of the Computer Fanout, therefore it is up to the Captain or Co-Captain to relay the information to those who are not registered to receive the messages.

Most Block Watch offices will not conduct a Computer Fanout for just one block. When the Block Watch office does not provide this service, it is then the responsibility of the Captain and an Co-Captain to relay information specific to their block -- via the manual fanout.

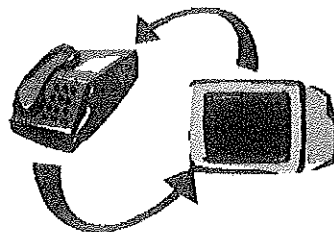

DWELLINGS OTHER THAN HOUSES ...

BLOCK WATCH WORKS PARTICULARLY WELL IN APARTMENTS, TOWNHOUSES AND MOBILE HOME COMPLEXES. IN THESE DWELLINGS, IT IS ORGANIZED IN A MANNER SIMILAR TO HOW RESIDENTIAL STREETS ARE SET UP. HOWEVER, A FEW ADJUSTMENTS ARE REQUIRED:

Usually, a complex coordinator or area coordinator is responsible for the organization and implementation of the Block Watch program for the entire development. The coordinator works with all the Captains, but is usually the person that acts as the liaison with the Block Watch office.

An overall map of the development is usually used with the development being broken into "blocks" of a convenient size for the Captains to manage.

EXAMPLES OF THIS ARE:

*One Captain per floor,
one Captain per six units
or perhaps a committee,
similar to your strata council.*

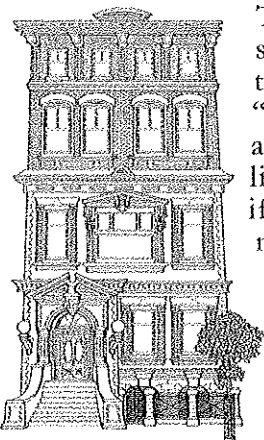

The map of the development should be included along with the individual maps of the "blocks" to each participant and the Block Watch office. In lieu of maps, lists may be used if you feel this would be a more appropriate method to keep in touch with your neighbours.

Here are a few things to consider:

- Is there a resident manager who can be part of the Block Watch system?
- Are all entrances key controlled?
- Are the building and parking areas well lit at night?
- Do units have good deadbolt locks and peephole viewers?
- Do you feel safe when alone in parking areas, laundry rooms, etc.?
- Will the manager allow you to re-key the locks if they are not adequate?
- Is there a security garage door or gate?
- Contact your landlord or manager and obtain his/her cooperation regarding the installation of any new home security devices.
- Use "M. Smith", not "Mary Smith", on the intercom board or mailbox. This is so that you don't let strangers know you live alone. It also conceals your gender.
- Don't leave notes on the door or buzzer panel.
- Report all suspicious activity to the police first, then to the manager and all block participants. Don't forget to call the Block Watch office.
- Don't hold the door or gate open for strangers, or "buzz" them in if they ring your unit. Have them ring the manager.
- Instruct your children on the correct procedure for admitting people.
- Lock your door even if you are leaving your unit for only a few minutes.
- Report all burned out lights to the manager and insist they be replaced immediately.
- Be sure to secure all doors and windows. The same goes for those in the garage, whether they are attached or not. Remember, garages are a good hiding place for a burglar.
- Make arrangements to provide access to emergency response personnel when a 911 call is made.
- If your intercom number is different than your suite number, remember to tell the operator taking your call.
- Remind residents to be sure the gate is closed after they enter or exit underground parking.
- Numbers on intercoms should be coded, so they don't match the suite number.

supported by:



BRITISH
COLUMBIA

Ministry of
Attorney General